



## Multi Range DC Power Supply PWR Series

- 3 types supporting rated output voltages of L (80 V), M (320 V), and H (650 V).  
3 types supporting maximum output powers of 400 W, 800 W, and 1600 W. 9 models in the series in total.  
Power supply with quintuple variable voltage/current range (3.25-times for the H type)  
Capable of outputting up to 160% of the rated current (extended operation areas) (L type)

**With a single PWR series power supply alone, you can cover an extensive output range equivalent to what is provided by three to six conventional single range DC power supplies.**

Multi Range DC Power Supply

# PWR series



**3 types of L, M, and H  
Lineup of 9 models in total!**

## Provides a seamless, wide, variable range of voltages and currents.

The PWR series offers DC power supplies that enable you to combine a multi range of voltages and currents within the output power rating. The series has a lineup of 9 models in total, 3 types supporting rated output voltages of L, M, and H and 3 types supporting different maximum output powers.

The L and M types offer a quintuple variable range of voltages and currents. The L type is capable of outputting up to 80 V, and the M type up to 320 V. In addition, the L type is capable of outputting up to 160% of the rated output current. (See Operation Area.)

The H type offers a 3.25-times variable range of voltages and current, and is capable of outputting up to 650 V.

### Operation Area

#### PWR-L (80 V type)

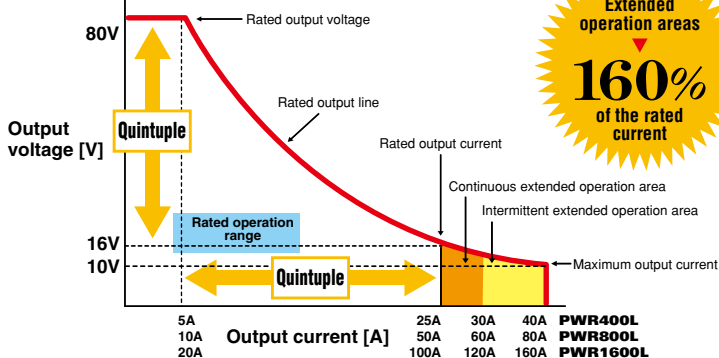

#### [Extended operation areas]

The L type offers extended operation areas equivalent to up to 160% of the output current rating. Some of the specifications may not be satisfied in the extended operation areas.

- Continuous extended operation area (up to 120% of the output current rating): Continuous current output is enabled. However, derating occurs at an ambient temperature 30°C or higher.
- Intermittent extended operation area (120% to 160% of the output current rating): Continuous current output is enabled for 10 minutes or less. However, a nonoperating period more than twice the output period must be taken.

#### PWR-M (320 V type)

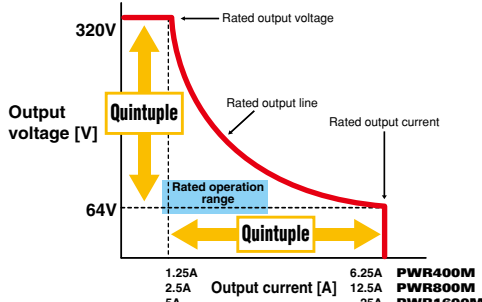

#### PWR-H (650 V type)

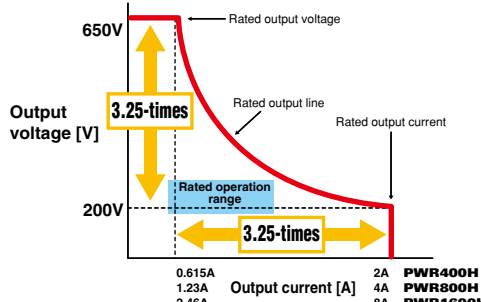

# Very Convenient and Economical Power Supplies That Serve Multiple Purposes.

The PWR series contributes to applications in which the environment greatly changes, such as tests with varying voltages and currents and research and development experiments with the voltage and current ranges varying widely depending on the item under development.

## ●Applications

- [Car electronics components]..... EPS motor, Radiator, Fan motor, DD converter, Vehicular harness, ECU, Door lock, Power window, HID lamp, etc.
- [Electronic components]..... TFT back light, photovoltaic inverter, DD converter, etc.
- [Batteries]..... Lead battery, sealed battery, etc.
- [Communication equipment]..... Switches, communication servers, etc.
- [Tests]..... Suitable for applications for which a test voltage or current is not determined

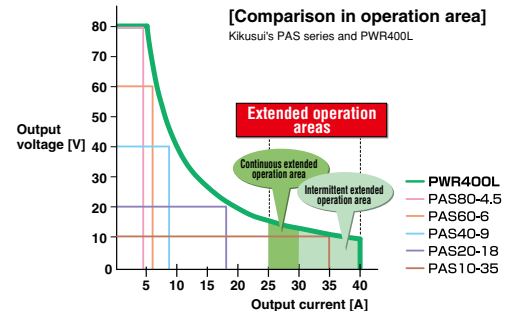

## Parallel Operation Possible

Parallel operation enables multiple power supplies of the same model to operate in parallel, offering a large capacity of up to 8 kW (when five 1600-watt models are connected in parallel).

## Front Output Terminals Included as Standard.

The power supplies have front output terminals (up to 30 A) for desktop use.

## ●Panel Description (400-Watt Type)

**SHIFT**  
Pressing a switch lit in blue while holding down this switch enables the function corresponding to that blue-lit switch.

**CONFIG**  
Turning on the power while holding down this switch starts the power supply in the CONFIG state, in which you can configure the settings related to the system operation.

**LOCK**  
Pressing this switch disables all the switches other than the output on/off switch.

**ADDRESS**  
Press this switch to set a node address in the range of 05 to 36 for digital remote control.

**POWER**  
This is the power switch.

**OUTPUT**

**VOLTAGE/PWR\_DSPL**  
Choose between Coarse and Fine (number of digits) for voltage setting.

**CURRENT/PWR\_DSPL**  
Choose between Coarse and Fine (number of digits) for current setting.

**SET**  
Press this switch to set or check the output voltage and current values.

**OVP/OCP**  
Press this switch to set or display the OVP (over voltage protection) and OCP (over current protection) operating voltages and currents.

**Dial**  
Change the voltage, current, and other set values.

**DC OUTPUT (front output terminals)**

**DC OUTPUT**

**Sensing terminal**

**Air vent**

**J1 connector**  
Use this connector to select the analog remote control, serial/parallel operation, and other functions.

**TP-BUS connector**  
Use this connector to connect the power supply to Kikusui's PIA4800 series controller using a twisted pair wire for digital remote control.

**AC INPUT**  
Note: This will be a terminal board for the 1600-watt type.

## Digital Communication Function (TP-BUS) Included as Standard.

In addition to an analog external control, a digital communication function (TP-BUS) is included as standard. When used with a power supply controller (PIA4830), which is an option to be purchased separately, the function enables up to 32 PWR series power supplies to be controlled using the GPIB or RS-232C interface. In addition, the sequence generation software (Wavy for PWR+PIA4830), allows users to exert output control over a single PWR series power supply with sequence patterns of their choice and to read result data. (If controlling more than one power supply with Wavy, contact us for consultation.)

### ●Power supply controller PIA4830

GPIB/RS-232C interface unit.  
Up to 32 PWR series power supplies can be controlled with one PIA4830 controller.

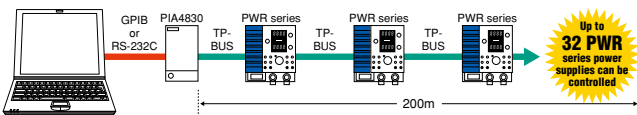

### ●Sequence generation software Wavy for PWR+PIA4830

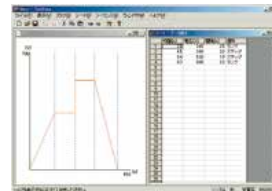

Wavy's screen example

#### Features/functions

- Waveform images can be generated easily using the mouse.
- Sequences can be developed and edited with ease.
- Voltages and currents can be monitored and saved in files.
- Text files can be read freely.
- \*OS: Windows 98/Me/2000/XP

## ●Options

- Analog remote control connector kit: OP01-PAS  
Connect the provided connector to the J1 connector on the rear side for external control.  
[Content] 26-pin connector, semi-cover, pin (× 10), and ground cable
- Carrying handle (for PWR400L): CH01-PWR
- Rack mount adapter (for 400W / 800W MODEL)  
**KRA3** (EIA-compatible inch rack)  
**KRA150** (JIS-compatible millimeter rack)
- Rack mount bracket (for 1600W MODEL)  
**KRB3-TOS** (EIA-compatible inch rack)  
**KRB150-TOS** (JIS-compatible millimeter rack)



# Specification

- \* The L type offers extended operation areas equivalent to up to 160% of the output current rating. Some of the specifications may not be satisfied in the extended operation areas.
- \* Continuous extended operation area (up to 120% of the output current rating): Continuous current output is enabled. However, derating occurs at an ambient temperature 30°C or higher.
- \* Intermittent extended operation area (120% to 160% of the output current rating): Continuous current output is enabled for 10 minutes or less. However, a nonoperating period more than twice the output period must be taken.

Specification		Output			Constant voltage (CV) characteristics				Constant current (CC) characteristics			Power input/Miscellaneous		
Model	CV	CC	Rated power	Ripple	Line regulation	Load regulation	Transient response	Ripple	Line regulation	Load regulation	Input current	Inrush current	Weight	
	V	A	W	mVrms	0.05% + mV	0.05% + mV	ms	mArms	0.1% + mA	0.1%+mA	AC (100/200V) A	Apeak (Max)	kg (approx.)	
L type	0~80	PWR400L (LLC)	0~25 MAX 40*	400	10	3	5	1	40	10	10	6.5/3.3	35	5
		PWR800L (LLC)	0~50 MAX 80*	800	15	3	5	1.5	80	10	10	13.0/6.5	70	8
		PWR1600L (LLC)	0~100 MAX 160*	1600	20	3	5	2	160	10	10	26.0/13.0	140	15
M type	0~320	PWR400M (LLC)	0~6.25	400	15	3	5	4	25	10	10	6.25/3.13	35	5
		PWR800M (LLC)	0~12.5	800	20	3	5	8	35	10	10	12.5/6.25	70	8
		PWR1600M (LLC)	0~25	1600	25	3	5	12	50	10	10	25.0/12.5	140	15
H type	0~650	PWR400H (LLC)	0~2	400	20	3	5	6	10	10	10	6.0/3.0	35	5
		PWR800H (LLC)	0~4	800	30	3	5	7	20	10	10	12.0/6.0	70	8
		PWR1600H (LLC)	0~8	1600	40	3	5	8	40	10	10	24.0/12.0	140	15

NOTE: For the PWR series, the low leakage current type (LLC model) is also available. For more information, please contact us. Please note that the Low Leakage Current(LLC) type is not applied for the CE marked products.

## [Common specification]

Input power.....100 to 240 VAC (85 to 250 VAC), single-phase  
50 to 60 Hz (47 to 63 Hz)

Power factor.....0.98 standard

Efficiency.....70% or greater

Temperature coefficient...100 ppm/°C for constant voltage output  
200 ppm/°C for constant current output

Measuring meters.....Voltmeter (23°C ±5°C)

Maximum display (fixed point): 99.99 (L type), 999.9 (M and H types)

Display error: ±(0.2% of rdng + 5 digits) [rdng = reading]

Ammeter (23°C ±5°C)

Maximum display (fixed point)

Maximum output current	Maximum display digits
Models supporting 10 A or less	9.999
Models supporting 10 to less than 100 A	99.99
Models supporting 100 A or greater	999.9

Display error: ±(0.5% of rdng + 5 digits) [rdng = reading]

Protection function.....\* Over voltage protection (OVP): Setting range (10% to 110% of the rated output voltage)

\* Over current protection (OCP): Setting range: (10% to 110% of the rated output current) for the M and H types

Setting range: (10% to 176% of the rated output current) for the L type

\* Over power protection (OPP): Approx. 110% of the rated output power or greater

\* Over heat protection (OHP): Operates due to an internal temperature rise.

\* Power limit (POWER LIMIT): Power limit imposed at approx. 105% of the rated output power.

Parallel operation.....Up to 5 units including master (of same model)

Serial operation.....Up to 2 units including master (of same model, for the L type only)

Digital control.....TP-BUS (directly controllable from PIA4810/PIA4830)

Monitor signal output...VMON (at rated voltage output), IMON (at maximum current output): 10.00 ±0.25 V

Status signal output:....OUT ON/CV/CC/ALM/PWR OFF/PWR ON

Environmental conditions...Operating ambient temperature range: 0°C to +50°C

Derating occurs on output current at 45°C or higher for the L type and 40°C or higher for the M/H types.

\* Operating ambient humidity range: 20% to 85%rh (non-condensing)

\* Storage temperature range: -25°C to +70°C

\* Storage humidity range: 90%rh or less (non-condensing)

Cooling system.....Forced air cooling (thermal control: Fan control function attached)

Ground polarity.....Negative or positive ground polarity possible.

Ground voltage.....±600 Vmax for the L and M types

±1000 Vmax for the H type

Electromagnetic compatibility...Conformance to the requirements of the directives and standards below.

EMC Directive 89/336/EEC

EN61326 : 1997/A2 : 2001 Emission : Class A

Immunity : Minimum immunity test requirements

EN61000-3-2 : 2000

EN61000-3-3 : 1995/A1 : 2001

(\*Not applicable to custom-made modified products.)

(\*Only those models with CE marking provided on their panel.)

Safety.....Conformance to the requirements of the directive and standard below.

Low Voltage Directive 73/23/EEC

EN61010-1:2001 Class I, Overvoltage Category II, Pollution Degree 2

400-watt type: 106.5 W × 124 (145) H × 400 (470) D mm

800-watt type: 214 W × 124 (155) H × 400 (470) D mm

1600-watt type: 428.5 (450) W × 128 (150) H × 400 (470) D mm

\*Enclosed in parentheses are maximum dimensions.

Accessories.....Instruction manual, power cord (400-watt type: Approx. 2.4 m in length, with a plug; 800-watt type: Approx. 3 m in length, with a plug; 1600-watt type: 3m in length, without a plug)

Rear side output terminal protection cover, TP-BUS connector, J1 dummy connector, output terminal screws, etc.

## [Dimensions drawing Units: mm]

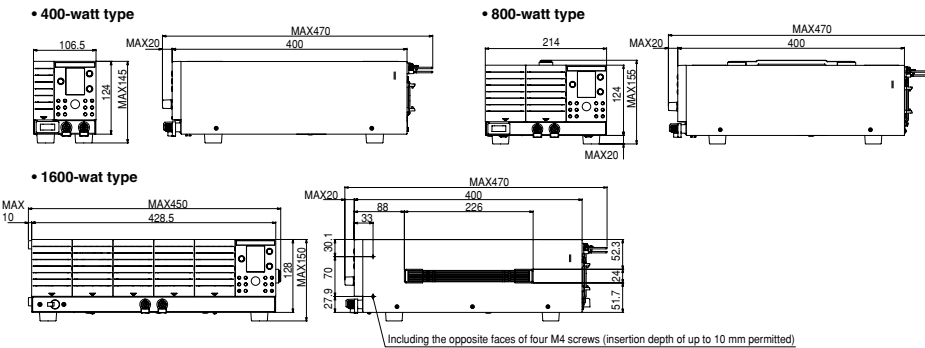

## KIKUSUI ELECTRONICS CORPORATION

1-1-3, Higashiyamata, Tsuzuki-ku, Yokohama, 224-0023, Japan

Phone: (+81) 45-593-7570, Facsimile: (+81) 45-593-7571, www.kikusui.co.jp

KIKUSUI AMERICA, INC. 1-877-876-2807 [www.kikusuiamerica.com](http://www.kikusuiamerica.com)



2975 Bowers Avenue, Suite 307, Santa Clara, CA 95051  
Phone : 408-980-9433 Facsimile : 408-980-9409

KIKUSUI TRADING (SHANGHAI) Co., Ltd. [www.kikusui.cn](http://www.kikusui.cn)



Room 216, Building 4, No.641, Tianshan Road, Shanghai City, China  
Phone : 021-5887-9067 Facsimile : 021-5887-9069

For our local sales distributors and representatives, please refer to "sales network" of our website.

## ●Distributor:

■ All products contained in this catalogue are equipment and devices that are premised on use under the supervision of qualified personnel, and are not designed or produced for home-use or use by general consumers. ■ Specifications, design and so forth are subject to change without prior notice to improve the quality. ■ Product names and prices are subject to change and production may be discontinued when necessary. ■ Product names, company names and brand names contained in this catalogue represent the respective registered trade name or trade mark. ■ Colors, textures and so forth of photographs shown in this catalogue may differ from actual products due to a limited fidelity in printing. ■ Although every effort has been made to provide the information as accurate as possible for this catalogue, certain details have unavoidably been omitted due to limitations in space. ■ If you find any misprints or errors in this catalogue, it would be appreciated if you would inform us. ■ Please contact our distributors to confirm specifications, price, accessories or anything that may be unclear when placing an order or concluding a purchasing agreement.

Printed in Japan

Issue:Oct.2010

201010PDF EC81