

C B A 1 0 0 0

CIRCUIT BREAKER ANALYZER AND MICROOHMMETER



Circuit Breaker Analyzer and MicroOhmmeter

- Circuit Breaker timing test set
- Built-in 200 A microOhmmeter
- 16 timing channels
- Up to 4 trip/close coils control
- Motion and speed analyzer
- Static and dynamic contact resistance measurement
- Suitable for EHV, HV and MV circuit breakers
- Stand alone functionality - no PC connection is required
- Large graphical high brightness sunlight display
- Analysis and result evaluation directly on the display
- Internal memory for up to 250 test results and 64 pre-defined test plans.
- Cross trigger for the synchronization of up to 4 CBA 1000
- Circuit Breaker test with both ends connected to ground (BSG option)
- TDMS software for test results analysis and reporting.

A P P L I C A T I O N

CBA 1000 is a unique tool for the complete test of all circuit breakers. It is a powerful timing and motion analyzer test set with built-in 200 A pure DC current microOhmmeter for static and dynamic contact resistance tests.

CBA 1000 is a stand alone unit with a large graphical display. The unit is supplied with TDMS analysis software. TDMS performs test results analysis and creates test reports; it allows also to pre-define test plans. TDMS is also a powerful Test and Data Management software, compatible with all ISA Test Sets.

All CBA 1000 circuits have been designed to ensure safe and reliable operations in the noisy environment of HV / MV substations and power plants.

C H A R A C T E R I S T I C S

Coil operation

- Number of circuits: 2 (1 Open and 1 Close coils); optional 4 (3 Open and 1 Close coils).
- Type of driver: electronic; it ensures superior timing control.
- Driver characteristic: 300 V DC max; 30 A DC max.
- Operating time accuracy: 0.025% of delay \pm 100 μ s.
- Measurement of the coil current: one per channel; the waveform is displayed on the dedicated channels.
- Coil current ranges: 2.5; 10; 25 A full scale, user selectable.

- In case of 4 coils option, it is possible to select the single or multiple phase opening.
- Coil current measurement accuracy: 0.5% of the reading \pm 0.1% of the selected range.
- Outputs are isolated between them.

Main contact inputs

- Number of contact inputs: 6 Main contacts (2 break per phase) plus 6 Resistor contacts (2 break per phase).
- Resistor contact ranges: from 20 Ohm to 10 kOhm.
- Contact test voltage: 24 V. Main contact test current: 50 mA.
- Each input group is isolated with respect to the others.

Event inputs

- Number of auxiliary event inputs: 4, divided in 2 groups of 2 each.
- Capability of testing dry (24 V) or wet contacts (20 to 300 V). Test current: 2 mA.

Sample rates

20 kHz - 10 kHz - 5 kHz - 2 kHz - 1 kHz - 500 Hz - 200 Hz - 100 Hz, 50 Hz, 20 Hz user selectable.

Timing accuracy

100 μ s \pm 0.025% of the time reading at 20 kHz.

Maximum record length

1000 s.

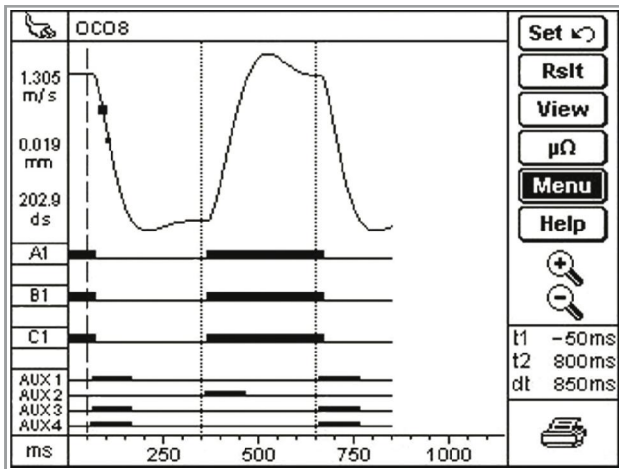

CBA 1000 test result display

Analog inputs

- Number of analog inputs: 4 (6 Optional).
- 2 (4 optional) dedicated to Open and Close coil currents.
- 1 dedicated to Dynamic and Static Resistance Measurement.
- Input voltage range: ± 5 V.
- 1 dedicated to travel, velocity, station battery voltage, etc.
- Input voltage range: ± 5 V; ± 50 V; ± 500 V, user selectable.
- Analog inputs are isolated with respect to all other circuits.
- Analog input measurement resolution: 16 bit.

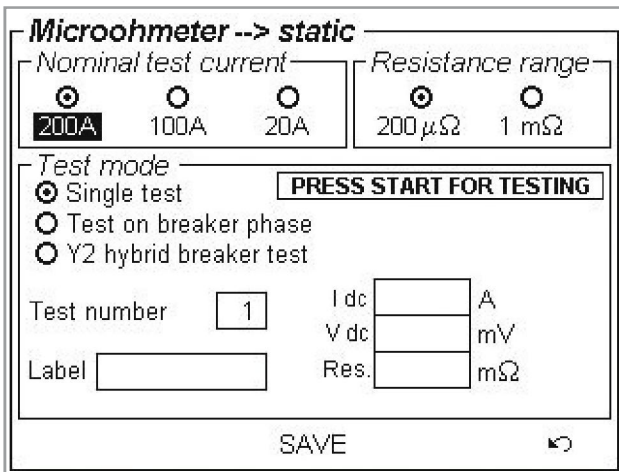

Microhmmeter display

Programmable sequences

The user can select the following Open and Close sequences:
Open; Close; Open-Close; Close-Open; Open-Close-Open.

Static and Dynamic resistance measurement (Option)

- DC Test current: 200 A, 100 A, 20 A.
- Resistance measurement ranges 200 $\mu\Omega$; 1 m Ω ; 10 m Ω ; 100 m Ω , user selectable.
- Resolution: 0.1 $\mu\Omega$; 1 $\mu\Omega$; 10 $\mu\Omega$; 100 $\mu\Omega$.

- Resistance measurement accuracy: 1% of the reading \pm 0.2% of the range.

Minimum trip Voltage test (Option)

The minimum trip voltage test allows to verify the minimum trip voltage threshold and the voltage drop-off delays.

- Two options: 250 V Max and 70 V Max.
- Maximum current: 4 A (250 V); 10 A (70 V).
- Maximum voltage adjustment: up to 50% of V Max.

Internal or external Printer (Option)

- Optional internal thermal printer 58 mm wide.
- Optional external thermal printer: Seiko DPV-414, 112 mm wide.

Test set control

- The control is local, via graphical display, keypad and pushbutton for menu selection: no PC control is necessary.

Display

Large graphical high brightness sunlight display (viewing area 122 x 92 mm).

Test results are displayed graphically and in table format.

Zoom functions and cursors for test data analysis are directly available on the CBA 1000 display.

Interfaces to PC

2 available interfaces: USB and RS232.

Memory size

128 Mbytes (approx. 250 results).

TDMS software

TDMS is a powerful software package, providing data management for commissioning and maintenance testing activities. Circuit breaker data and test results are saved in the TDMS database for historical results analysis.

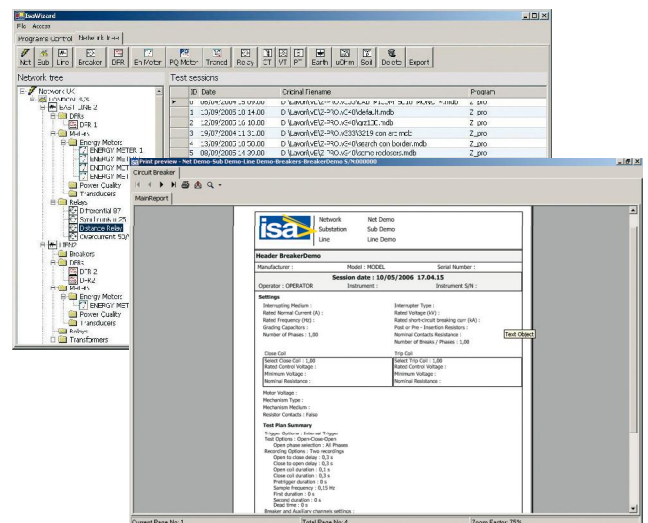

Test & Data Management Software



TDMS software has the following main features.

- . Full control of CBA 1000 functions from PC.
- . Download of test plans.
- . Download of test results.
- . Test plans and test results can be viewed, edited in the missing descriptions, saved, printed, exported.
- . Possibility of viewing, overlaying and gluing more results, for an easy test result comparison.
- . Possibility to pre-set test plans and to upload them into the test set.
- . Two cursors select measurement points and intervals.
- . Zoom in and out feature.
- . Enhanced measurement features for movement - speed - acceleration control.

ISA software updating policy allows all users to update their software from the ISA web site www.isatest.com, at no additional cost.

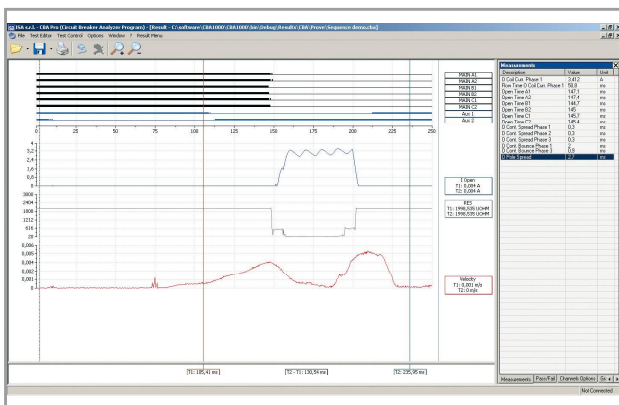

Test result analysis

Other characteristics

CBA 1000 can operate both from mains (AC or DC) and from an internal rechargeable battery:

- . Mains supply:
 - . From 85 to 265 V AC; 50-60 Hz.
 - . From 100 to 350 V DC.
- . Internal battery. Battery type: NiMh.
- . Case: aluminium, with hinged removable cover and handle.
- . Dimensions: 400(W) * 300(D) * 240(H) mm. Weight: 10 kg basic unit; 11 kg with Microhmeter module.

STANDARD ACCESSORIES

The following accessories are supplied with the unit:

- . Mains cable
- . User's manual for hardware and software
- . Serial cable
- . Grounding cable
- . USB cable
- . Spare fuses
- . Software TDMS.

OPTIONAL ACCESSORIES

The following options are available upon request:

. Basic unit test cable kit

The set includes:

- . N. 3 Cables for connection to Main contacts;
- . N. 2 Cables for connection to Auxiliary contacts;
- . N. 1 Cable for connection to Breaker Coils.
- . N. 1 Cable for Low Voltage Measurement.
- . N. 1 Kit of adaptors and N. 1 adaptor 15 cm long.
- . N. 1 Cable for connection to Transducers.
- . N. 1 Kit of auxiliary cables and a kit of crocodile clamps.
- . Transport Plastic bag.

. Additional 2 Open driving coils module

This module increases to 3 the number of Open Coils.

- . **Built-in 200 A Static / Dynamic resistance module** with 10 m long test cables, cross section 25 sq.mm, terminated with high current clamps.
- . **Minimum trip Voltage test**
- . **Internal thermal printer.** CBA 1000 has an (optional) built-in thermal printer, 58 mm wide.
- . **BSG 1000** is an enhanced safety external module, that allows to test the circuit breaker with both sides connected to ground.
- . **CBA Heavy duty transport case with wheels.**
- . **CBA plastic soft bag.**

. Linear transducer

- . Linear transducer: TLH 150 - 150 mm length (IP40).
- . Linear transducer: LWG 150 - 150 mm length.
- . Linear transducer: TLH 225 - 225 mm length (IP40).
- . Linear transducer: LWG 225 - 225 mm length.
- . Linear transducer: TLH 300 - 300 mm length (IP40).
- . Linear transducer: TLH 500 - 500 mm length (IP40).
- . Linear transducer: LWG 500 - 500 mm length.
- . **Pressure transducer:** PA-21 Y 40 BAR.
- . **Rotary transducer:** IP 6501 - 355° rotation angle.
- . **Universal transducer mounting kit** for TLH, LWG and IP travel transducers.
- . **Hall effect clip-on transformer.** It allows measuring the DC current of motors and of the auxiliary supply.

APPLICABLE STANDARD

The test set conforms to the EEC directives regarding Electromagnetic Compatibility and Low Voltage instruments.

. Electromagnetic Compatibility:

Directive 2004/108/EC (CE conform). Applicable standard: EN 61326:2006.

. Low Voltage Directive:

Directive 2006/95/EC (CE conform).

. Applicable standards, for a class I instrument, pollution degree 2, Installation category II: CEI EN 61010-1. In particular:

- . Inputs/outputs protection: IP 2X - CEI EN 60529.
- . Operating temperature: -10°C to 55 °C; storage: -20°C to 70 °C.
- . Relative humidity: 10 - 95% without condensing.

ORDERING INFORMATION

CODE	MODULE
10166	CBA 1000 basic unit supplied with
10015	TDMS - Test & Data Management Software



CBA 1000 - Transport Case

OPTIONAL ACCESSORIES

CODE	MODULE
15166	CBA1000 Test Cables Kit with transport case
43166	Additional 2 Open Coils Module*
23166	200 A Static / Dynamic Resistance Module (with test cables 10 m terminated with clamps)*
33166	Internal Thermal Printer*, **
14102	External Thermal Printer 4.5"
18166	Heavy Duty Plastic Transport Case
19166	Plastics soft bag
34166	MTC - Minimum Trip Coil test module*, **
11166	TLH 150 Linear Transducer 150 mm
12166	TLH 225 Linear Transducer 225 mm
36166	TLH 300 Linear Transducer 300 mm
13166	TLH 500 Linear Transducer 500 mm
14166	Rotary Transducer: IP 6501 – 355° rotation angle
26166	LWG 150 Linear Transducer 150 mm
27166	LWG 225 Linear Transducer 225 mm
28166	LWG 500 Linear Transducer 500 mm
13169	Pressure Transducer PA-21 Y 40 BAR
29166	Hall effect clip-on transformer
16166	Universal Analogic Transducer mounting kit
44166	Flexible Coupling Shaft



CBA 1000 - Cable Transport Case



CBA 1000 - Soft Bag Case

Options with * must be specified at order.
Options with ** are exclusive each other: code 33166 Internal thermal printer cannot be ordered together with code 34166 Minimum Trip Voltage Test Module.

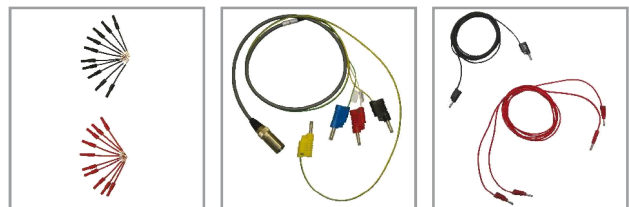
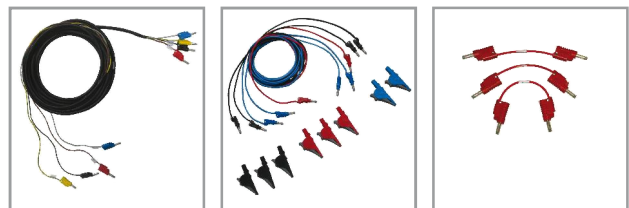
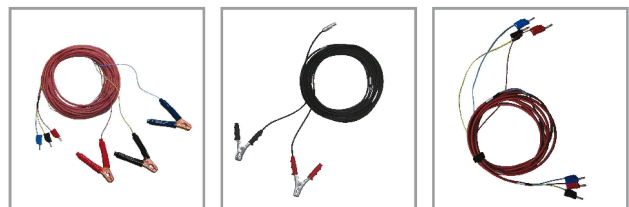

Transducer case



Mounting Kit



Hall effect clamp



TLH Linear Transducer



LWG Linear Transducer



Rotary Transducer

CBA 1000 - Example of test cable kit

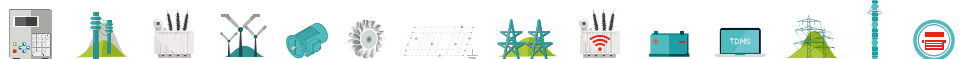



Safe Circuit Breaker test with both sides grounded

- Option for ISA Circuit breaker Analyzers CBA 1000 and CBA 2000
- Work safely while testing
- Save circuit breaker testing and analysis time
- Preserve all timing and motion test integrity
- BSG 1000 allows the test of circuit breakers using Graphite Nozzle
- This method applies to all kinds of circuit breakers.

I N T R O D U C T I O N

With the BSG option it is possible to perform the circuit breaker timing test with both sides grounded.

The grounding connection is NOT removed during the test, as it has to be with conventional test equipment.

Safety is becoming more and more important, and several laws and regulations all around the world prescribe that, at the work location in high voltage installation, all parts which are to be worked on, shall be earthed (grounded) and short circuited. While testing a Circuit Breaker in high voltage substations the situation may become dangerous due to the high electric potential. This can be caused by a capacitive coupling from a close conductor or when lightning strikes the line somewhere, or when a fault occurs during the test and a high potential reaches the circuit breaker.

To improve personnel safety, reduce hooking time and preserve the test set integrity, the use of BSG 1000 is the best practice. BSG 1000 is also the best solution for testing Circuit Breakers equipped with Graphite Nozzles.



D E S C R I P T I O N S P E C I F I C A T I O N

Two BSG 1000 types are available:

- BSG 1000- type 1 for testing one break per phase;
- BSG 1000- type 2 for testing two breaks per phase.

Each BSG 1000 is made of the following elements:

- . Three BSG Remote Heads, connected close to the main breaker contacts.

Remote Heads for BSG 1000- type 1

- . Each head has two cables, 2.5 m long, cross section 4 mm², terminated with crocodile clamps.
- . One bipolar shielded cable, 3 m long, terminated with crocodile clamps.
- . One 8 m long cable, terminated with multi-pole connectors for the connection between Remote Heads and the BSG Main unit.

Remote Heads for BSG 1000- type 2

- . Each head has three cables, 2.5 m long; cross section 4 mm², terminated with crocodile clamps.
- . Two bipolar shielded cables, 3 m long, terminated with crocodile clamps.
- . One 8 m long cable, terminated with multi-pole connectors for the connection between Remote Heads and the BSG Main unit.
- . One BSG Main unit, connected to the CBA 1000 or CBA 2000 circuit breaker analyzer.
- . Connection of BSG Main Unit to CBA 1000: via a cable 1 m long, terminated with a multi-pole connector.

- . Number of main contact inputs (type BSG 1000-1): 3, divided in three groups.
- . Number of main contact inputs (type BSG 1000-2): 6, divided in three groups of two each.
- . Test current injection: 20 A DC nominal.
- . Maximum test duration (each test): 1 s
- . Graphite nozzles test selection in the menu.



CBA 1000 connected to BSG 1000



BSG 1000 - Remote Head, type 1

Mains supply

- . From 85 to 265 V AC; 50-60 Hz, and;
- . From 100 to 350 V DC.
- . Maximum supply current: 1 A @ 85 V AC.

Weight and dimensions

BSG 1000 main unit

- . Case: aluminium case, with hinged removable cover and handles.
- . Weight: 6 kg
- . Dimensions: 325 x 180 x 285 (W x H x D)

BSG 1000 remote heads (three units)

- . Case: die-cast aluminium case.
- . Weight: 0,7 kg (without cables)
- . Dimensions: 125 x 56 x 125 (W x H x D)



ORDERING INFORMATION

CODE	MODULE
22166	BSG 1000 One break per phase including: . No 3 BSG Remote Heads Type1 . No 1 BSG Main unit . No 1 Cables kit
21166	BSG 1000 Two breaks per phase including: . No 3 BSG Remote Heads Type2 . No 1 BSG Main unit . No 1 Cables kit
17166	Heavy duty plastic transport case for BSG 1000

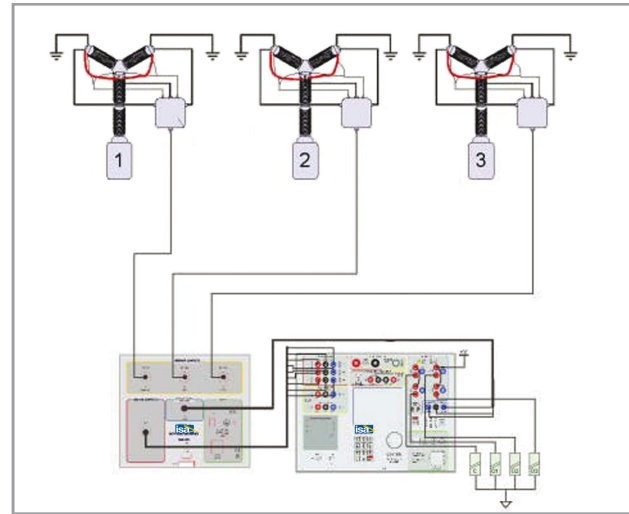

CBA 1000 connected to BSG 1000 and circuit breakers